



HI-TECH MEDICS
PRIVATE LIMITED

www.hitechsyringes.com



**The Widest
Choice Of
Medical Devices**



ABOUT US

- Founded in 1994 in Eastern part of Uttar Pradesh, India to provide world class medical devices.
- In 30 years, it has become one of the largest and fast-growing medical devices company in India.
- Supply to prestigious government, Institutional and private market across India and key international market.
- It has annual installed capacity of 1.4 billion syringes and produce disposable syringes from 1ml to 50ml with Luer Slip, Luer Lock and Auto Destruct AD features.
- The company is manufacturing Disposable Syringes with Luer Slip, Luer Lock and AD, Hypodermic Needles, I.V. Cannula/Catheters, Insulin Syringe and Infusion Sets.
- All our products adhere to European standards and have earned accreditation from TUV SUD – Germany under EU MDR.
- Exporting products to more than 30 countries globally.



QUALITY AND COMMITMENT

That Can't be Replaced

Do you know what makes us distinct from the rest? It's our conviction to deliver the quality and commitment no one else can offer. Let's see how we make it happen:-

- Strict adherence to industry regulations and standards at every stage of production
- Rigorous testing and inspection protocols to ensure flawless manufacturing
- Continuous improvement processes to stay ahead of changing requirements

We strictly follow the guidelines issued by BIS, ISO 13485, EU CE, and FDA for the manufacturing process and quality control routine quality checks consisting of physical, chemical, microbiological tests and Internal audits of the tests by the global team of experts to ensure the integrity of our products from raw materials through finished goods.

You can trust our products because quality and safety are built into our entire operation. We aim to exceed both regulatory standards and customer expectations. Our quality team is constantly finding ways to refine procedures and improve training to prevent issues. We know patients rely on our products, so defect prevention and reliability are our top priorities.

Through checking of each batch of products in the lab continuous supervision of production process, quality control and working condition by ISO, government inspectors, and other certified agencies.



CERTIFICATES

ZERTIFIKAT ◆ CERTIFICATE ◆ CERTIFICADO ◆ CERTIFIKAT ◆ 証明書 ◆ 證



EU Quality Management System Certificate (MDR)
Pursuant to Regulation (EU) 2017/745 on Medical Devices, Annex IX Chapters I and III (Class IIa and Class IIb Devices)
No. G10 118999 0002 Rev. 00

Manufacturer: **Hi-Tech Medics Private Limited**
AL-4, Sector -13, GIDA
Gorakhpur, Uttar Pradesh 273209
INDIA

SRN Manufacturer - IN-MF-00003105

Authorized Representative: EUCEREP B.V.
Rood Drijsen 33, 5629 MC Eindhoven, THE NETHERLANDS

The Certification Body of TÜV SÜD Product Service GmbH certifies that the manufacturer has established, documented and implemented a quality management system as described in Article 10 (9) of the Regulation (EU) 2017/745 on medical devices. Details on device categories covered by the quality management system are described on the following page(s). The Report referenced below summarises the result of the assessment and includes reference to relevant ISO harmonized standards and test reports. The conformity assessment has been carried out according to Annex IX Chapter I and III of this regulation with a positive result. The quality management system assessment was accompanied by the assessment of technical documentation for devices selected on a representative basis. The certified quality management system is subject to periodical surveillance by TÜV SÜD Product Service GmbH. The surveillance assessment shall also include an assessment of the technical documentation for the device or devices concerned on the basis of further representative samples. All applicable requirements of the Testing, Certification, Validation and Verification Regulations TÜV SÜD Group have to be complied with. For details and certificate validity see: www.tuvsud.com/ps-cert?cert=G10.118999.0002.Rev.00

Report No.: TP61367
Valid from: 2024-07-15
Valid until: 2029-07-17

C.Dick
Christoph Dick
Head of Certification/Notified Body

Issue date: 2024-07-18

Page 1 of 2
TÜV SÜD Product Service GmbH is Notified Body with identification no. 0123
TÜV SÜD Product Service GmbH • Certification Body • Rosenstraße 65 • 80339 Munich • Germany

CE 0123

ZERTIFIKAT ◆ CERTIFICATE ◆ CERTIFICADO ◆ CERTIFIKAT ◆ 証明書 ◆ 證



Certificate
No. Q5 118999 0001 Rev. 00

Holder of Certificate: **Hi-Tech Medics Private Limited**
AL-4, Sector -13, GIDA
Gorakhpur, Uttar Pradesh 273209
INDIA

Facility(ies): **Hi-Tech Medics Private Limited**
AL-4, Sector -13, GIDA, Gorakhpur, Uttar Pradesh 273209, INDIA

Certification Mark:



Scope of Certificate: **Design and Development, Production, Distribution of Sterile Single Use Syringes, Hypodermic Needle, Infusion Kit Single Use, Peripheral I.V. Catheters and Cannulas.**
ISO 13485:2016
(EN ISO 13485:2016/AC:2018, EN ISO 13485:2016/A1:2021)
Medical devices - Quality management systems - Requirements for regulatory purposes

Applied Standard(s):

The Certification Body of TÜV SÜD Product Service GmbH certifies that the company mentioned above has established and is maintaining a quality management system, which meets the requirements of the listed standard(s). All applicable requirements of the testing and certification regulation of TÜV SÜD Group have to be complied with. For details and certificate validity see: www.tuvsud.com/ps-cert?cert=Q5.118999.0001.Rev.00

Report No.: TP61367
Valid from: 2024-03-15
Valid until: 2027-03-14

C.Dick
Christoph Dick
Head of Certification/Notified Body

Date: 2024-03-15

Page 1 of 1
TÜV SÜD Product Service GmbH • Certification Body • Rosenstraße 65 • 80339 Munich • Germany

ISO 13485:2016



भारतीय मानक ब्यूरो
Bureau of Indian Standards
The National Standards Body of India

For any other communication

Lucknow Branch
Office-4th Floor, B-2
Block, PICUP
BHAWAN, Gomti
Nagar, Lucknow,
LUCKNOW,UTTAR
PRADESH,226010

Address:

Phone: 05222218923
Fax: 05222215698
E-Mail: lkbo@bis.gov.in
Web: www.bis.org.in,
www.manakonline.in

BUREAU OF INDIAN STANDARDS

Attachment to Licence No. CM/L- 9300096617

CM/L-No	Name of the Licensee with the Factory Address	Name of the Product	Indian Standard No.
9300096617	HI-TECH MEDICS PRIVATE LIMITED -AL-4, SECTOR -13, GIDA, Gorakhpur, Uttar Pradesh, Gorakhpur : 273209	Sterile Hypodermic Syringes for Single Use	IS 10258 : 2002

Endorsement No. 2 Dated 08-Jun-2024

Whereas, the licence was valid upto Fifteenth June Two Thousand Twenty Four.

Now, consequent upon renewal, the validity of the licence given in schedule of the Licence Dated 14-JUN-2024 has been extended from Fifteenth June Two Thousand Twenty Four to Fourteenth June Two Thousand Twenty Seven

Other terms and conditions of licence remain same.

Branch Head (Lucknow Branch Office)

Manak Bhavan, 9 Bahadur Shah Zafar Marg, New Delhi 110002, 9 Bahadur Shah Zafar Marg, DELHI, 110002

Contact No: +91 11 23230131, **Fax:** +91 11 23234062, 232 **Email:** info@bis.gov.in

BIS



CERTIFICATE OF COMPLIANCE

This is to Certify that
GOOD MANUFACTURING PRACTICE
OF
HI-TECH MEDICS PRIVATE LIMITED
AL-4, SECTOR-13, GIDA, GORAKHPUR, UTTAR PRADESH – 273209, INDIA,
has been independently assessed and is compliant with the requirements of
WHO-GMP
(WHO-Good Manufacturing Practice)
for the following scope:

FOLLEYS CATHETER, UROMETERWITH URINE BAG, CENTRAL VENOUS CATHETER SET, YANKUER SUCTION SET, ABDOMINAL DRAINAGE KIT, SUCTION CATHETER, CORD CLAMP, IV CANNULA, DOUBLE LUMEN CATHETER FOR HEMODIALYSIS, ARTERIAL, VENOUS FISTULA NEEDLE, THORACIC DRAINAGE CATHETER AND VOLUME CONTROLLED INTRAVENOUS ADMINISTRATION.

Certificate No : MQCI26M22
Initial Registration Date : 22/12/2022 **Issuance Date** : 22/12/2022
Date of Expiry : 21/12/2025 **2nd Surve. Date** : 21/12/2024
1st Surve. Date : 21/12/2023

Authorized Signatory



Validity of the Certificate Can be Verified at www.mqci.uk
Mark Quality Certification & Inspection UK LTD,
2 Fredrick Street, London, WC1X 9ND, UK,
Email info@mqci.uk

This Certificate's validity is subject to the organization maintaining their system in accordance with MQCI UK LTD's requirements for system certification. This Certificate remains the Property of Mark Quality Certification & Inspection UK LTD and shall be returned immediately upon request and remain valid subject to satisfactory Surveillance audits.

WHO-GMP

CONTENT

- 1 — **I.V. Cannula -With Wings & Injection Port**
- 2 — **Hypodermic Syringe - Luer Slip**
- 3 — **Hypodermic Syringe - Luer Lock**
- 4 — **Hypodermic Syringe - Auto Disable**
- 5 — **Insulin Syringe**
- 6 — **Hypodermic Needles**
- 7 — **I.V. Infusion Set**
- 8 — **Blood Transfusion Set**
- 9 — **Foley Balloon Catheters**
- 10 — **Urine Collection Bag**
- 11 — **Urine Collection Bag with Measured Volume Meter**
- 12 — **Umbilical Cord Clamp**

I.V. CANNULA

With Wings & Injection Port

Product Features

- Specially designed beveled back cut needle offers lower penetration force which is less painful to the patient.
- Needle hub designed for proper grip during insertion.
- Transparent flashback chamber for conformation of vein penetration.
- Specially made up of European catheter and Japanese needles, offer less penetration force.
- Needle cover designed for safe disposal of needle after catheterization.
- Color coded body for identification of gauge size.
- Sterile, non-pyrogenic.

Available:

- With radiopaque lines
- FEP Catheter

Size	Catheter OD (mm)	Needle OD (mm)	Water Flow Rate (ml/min)	ITEM CODE
14G	2.10	1.47	270	IVCO1
16G	1.80	1.25	200	IVCO2
18G	1.30	0.85	90	IVCO3
20G	1.10	0.70	60	IVCO4
22G	0.90	0.55	36	IVCO5
24G	0.73	0.45	23	IVCO6
26G	0.63	0.40	15	IVCO7

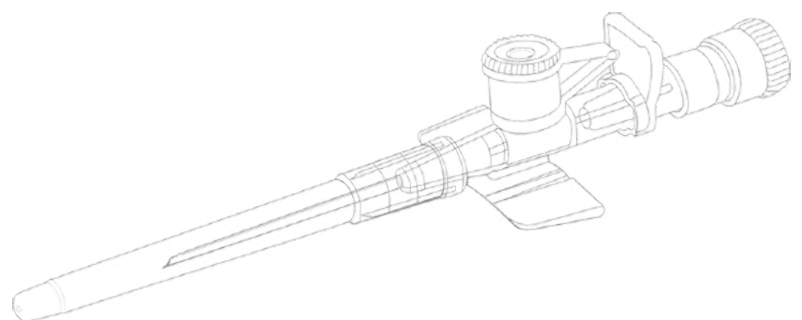

STERILE HYPODERMIC Syringes

Product Features

- High clarity transparent barrel molded by using premium quality medical grade polypropylene.
- Very sharp and clear graduation marks for precise dosage accuracy.
- Thermo Plastic Elastomer (TPE) Gasket for smooth movement of the plunger.
- Needles are manufactured by using imported cannula with precise tip sharpness and strong bonding strength with the hub.
- Needles have an ultra-thin wall permitting rapid and efficient Medicines Insertion.
- Smooth gliding action to reduce pain while injecting medicaments.
- **Sterile, non-toxic and pyrogen free.**

Available with or without needle.

SYRINGES SIZE	NEEDLE SIZE	INNER QUANTITY		SHIPPER QUANTITY		ITEM CODE
		RIBBON PACK	BLISTER PACK	RIBBON PACK	BLISTER PACK	
1ml	16G - 27G	100 Pcs	100 Pcs	2000 Pcs	2000 Pcs	HS01
2ml	16G - 27G	100 Pcs	100 Pcs	2700 Pcs	2700 Pcs	HS03
3ml	16G - 27G	100 Pcs	100 Pcs	2700 Pcs	2700 Pcs	HS04
5ml	16G - 27G	100 Pcs	100 Pcs	2400 Pcs	2400 Pcs	HS05
10ml	16G - 27G	50 Pcs	100 Pcs	1200 Pcs	1200 Pcs	HS06
20ml	16G - 27G	50 Pcs	50 Pcs	600 Pcs	600 Pcs	HS07
50ml	16G - 27G	25 Pcs	-	300 Pcs	-	HS08

LUER SLIP

Size

1ml 2ml 3ml 5ml 10ml 20ml 50ml

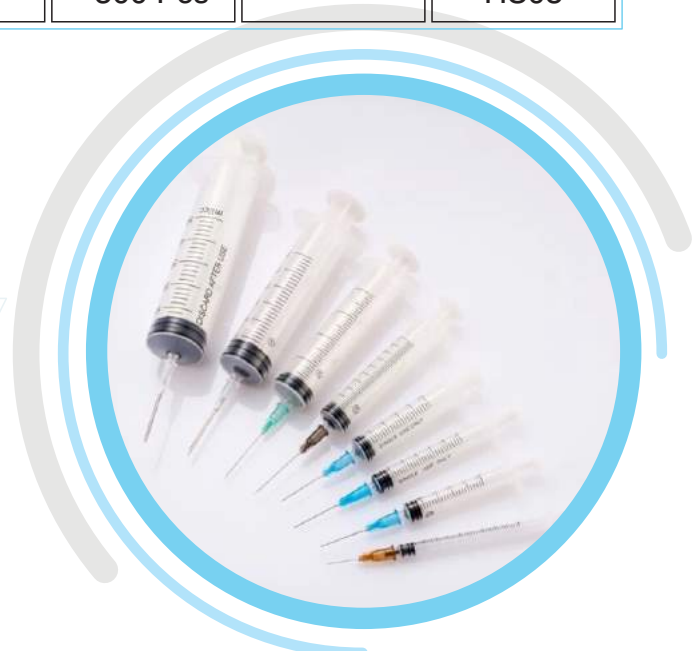

STERILE HYPODERMIC Syringes

LUER LOCK

Product Features

- The luer lock syringe has a threaded tip that securely locks the needle or other medical attachments in place. It ensures a tight, leak-proof connection between the syringe and the attachment.
- High clarity transparent barrel molded by using premium quality medical grade polypropylene.
- Very sharp and clear graduation marks for precise dosage accuracy.
- Thermo Plastic Elastomer (TPE) Gasket for smooth movement of the plunger.
- Needles are manufactured by using imported cannula with precise tip sharpness and strong bonding strength with the hub.
- Needles have an ultra-thin wall permitting rapid and efficient Medicines Insertion.
- Smooth gliding action to reduce pain while injecting medicaments.
- **Sterile, non-toxic and pyrogen free.**

Available with or without needle.

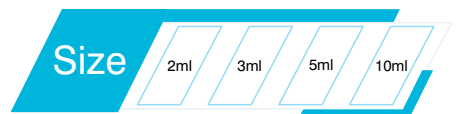

SYRINGES SIZE	NEEDLE SIZE	INNER QUANTITY		SHIPPER QUANTITY		ITEM CODE
		RIBBON PACK	BLISTER PACK	RIBBON PACK	BLISTER PACK	
2ml	16G - 27G	100 Pcs	100 Pcs	2700 Pcs	2700 Pcs	HS03
3ml	16G - 27G	100 Pcs	100 Pcs	2700 Pcs	2700 Pcs	HS04
5ml	16G - 27G	100 Pcs	100 Pcs	2400 Pcs	2400 Pcs	HS05
10ml	16G - 27G	50 Pcs	50 Pcs	1200 Pcs	1200 Pcs	HS06

AUTO DISABLE Syringes



Product Features

- High clarity transparent barrel molded by using premium quality medical grade polypropylene.
- Auto-Disable (AD) prevents the re-use of syringes.
- Highly transparent barrel & contrast black graduation.
- After completion of the dose, the plunger is automatically locked and will break when retracted.
- **Sterile, non-toxic and pyrogen free.**

SYRINGES SIZE	NEEDLE SIZE	INNER	SHIPPER	ITEM CODE
		RIBBON PACK	RIBBON PACK	
0.5ml	16G - 27G	100 Pcs	2700 Pcs	ADS01
2ml	16G - 27G	100 Pcs	2700 Pcs	ADS01
5ml	16G - 27G	100 Pcs	2400 Pcs	ADS01
10ml	16G - 27G	50 Pcs	1200 Pcs	ADS01

INSULIN Syringes



U 40

(ITEM CODE:INS01)



U 100

(ITEM CODE:INS02)

Product Features

- The high transparency of the barrel permits the end-user a strict control on the foreign substance and liquid flow.
- The medical-grade silicone oil is used as the lubricant for the purpose of getting a smooth plunger movement.
- The inerasable graduation permits an easy reading.
- Fixed needle, no dead space
- Ultra fine needle (29-31G)
- **Sterile, non-toxic and pyrogen free.**

Available: U40 and U100

Insulin Syringes	Inner Quantity	Shipper Quantity
POUCH PACK	100 Pcs	2000 Pcs
RIBBON PACK	100 Pcs	2000 Pcs
BLISTER PACK	100 Pcs	2000 Pcs

HYPODERMIC Needles



Product Features

- Assembled and packaged on totally automated machines.
- Cannula made from imported cold-rolled stainless-steel strips in-house.
- Top-quality stainless steel.
- Semi-transparent needle hub.
- Color-coded hub for clear recognition of needle size.

Size	Needle Diameter (mm)	Blister		ITEM CODE
		PCS/INNER BOX	PCS/OUTER BOX	
16G	1.60	100 Pcs	5000 Pcs	HN01
18G	1.20			HN02
20G	0.90			HN04
21G	0.80			HN05
22G	0.70			HN06
23G	0.60			HN07
24G	0.55			HN08
25G	0.45			HN09
26G	0.40			HN010
27G	0.40			HN011

INFUSION & TRANSFUSION SET



IV Infusion Set

(ITEM CODE: W/O & WITH AIR VENT: IVS01/IVS02)

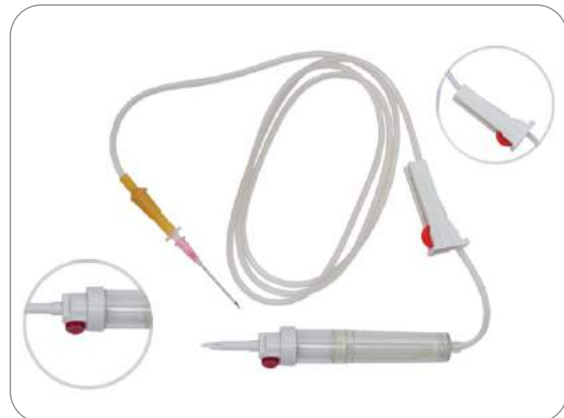

Blood Transfusion Set

(ITEM CODE: W/O & WITH AIR VENT: BTS01/BTS02)

I.V. Infusion Set

Product Features

- Flexible drip chamber to facilitate rapid adjustment of fluid.
- Manufactured from non-toxic and transparent material.
- Soft, kink resistant tubing.
- Sharp, sleek spike with vents to allow effortless penetration into the IV solution bag.
- Molded, self-sealing latex bulb at distal end for intermittent medication.
- Sterile and non-pyrogenic.

Available:

- With Airvent
- Without Airvent
- With Y-Site
- With Luer Lock

Blood Transfusion Set

Product Features

- Strong, sleek and sharp spike to puncture blood bag outlets.
- Transparent & flexible drip chamber.
- Soft and kink resistant PVC tubing.
- Regulator clamp to control transfusion rate.

Available:

- With Airvent
- Without Airvent
- Single Chamber
- Double Chamber

FOLEY BALLOON CATHETER



Foley Catheter 2 Way

(ITEM CODE:FBC2W-01)



Foley Catheter 3 Way

(ITEM CODE:FBC3W-01)

Product Features

- A ultra-slim exceptionally flexible inflatable and hard non-return valve for inconvenience free swelling and flattening.
- Made of Silicone elastomer fortified with latex rubber.
- Minimizes the risk of encrustation.
- Elliptical side-eye.
- Trauma free catheterization.
- Color-coded valve for easy identification.
- Minimizes subsequent catheter blockage and failure.

Available:

- 2-Way
- 3-Way

URINE COLLECTION BAG



Urine Bag

(ITEM CODE:UB2L-01)



Urine Bag with Urometer

(ITEM CODE:UBUM-01)

Urine Collection Bag

Product Features

- Provided with a long kink-resistant flexible transparent tube, cone connector with a cap and can fit any catheter size and type.
- Standardized with non-return valve.
- Integrated hanging system.
- Made of medical grade PVC.
- 2000 ml urine bag has side marks from 25 to 100 ml allowing to measure small urine volume.
- Transparent body to visualize urine color and volume.

Available:

- With outlet & with hanger, non-return valve
- With outlet & without hanger, non-return valve

Urine Collection Bag with Measured Volume Meter

Product Features

- Urometer has been designed for measurement of hourly urine output.
- Clear and Transparent measured volume chamber provides accurate measurement.
- Completely closed circuit eliminates the risk of contamination.
- Capacity of urine bag – 2000ml.
- Urine chamber directly attached to the urine bag with overflow facility.
- Screw type bottom outlet is provided for easy and quick emptying of urine bag.
- Universal tapered connector with sampling port facilitates mid stream urine sampling.

UMBILICAL CORD CLAMP



(ITEM CODE:UCC-01)

Product Features

- Designed for clamping the umbilical cord immediately after the birth.
- Finger grip ensures safe & convenient handling.
- Manufactured from non-toxic medical grade polymer.
- Provided with grooves all along the length.
- Protection against accidental re-opening.
- **Sterile, non-toxic and pyrogen free.**



HI-TECH MEDICS PRIVATE LIMITED



Email:

sales1@hitechsyringes.com

Contact Us:

+91 7897895558

ACCREDITATION



Europe

Manufacturing Standards

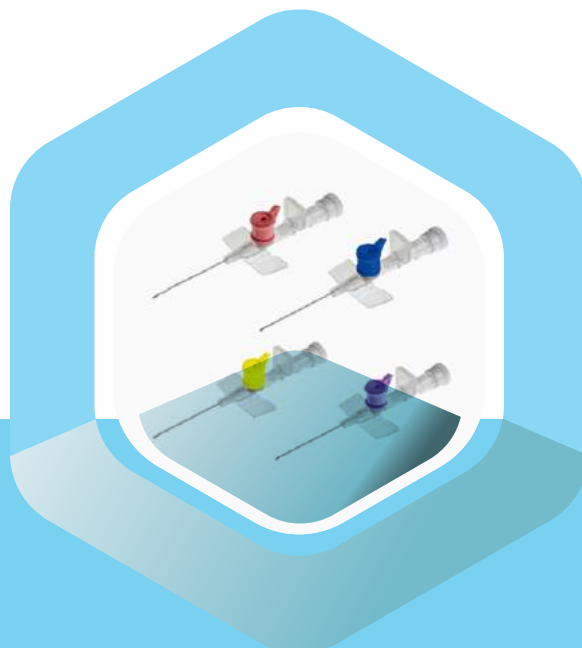

Corporate Office:

608 & 609, 6th Floor, Shalimar Titanium,
Vibhuti Khand, Gomti Nagar, Lucknow,
Uttar Pradesh-226010, INDIA

Email: contact@hitechsyringes.com

Landline: 0522-4338568

Factory At:

AL-4, Sector-13, GIDA, Gorakhpur,
Uttar Pradesh-273209, INDIA